

AC INDUCTION MOTOR CONTROLLERS



CURTIS

MODEL 1236/1238



DESCRIPTION

Curtis Models 1236 and 1238 provide advanced control of AC induction motors performing on-vehicle traction drive or hydraulic pump duties. They offer vehicle developers a highly cost-effective combination of power, performance and functionality.

APPLICATION

Designed primarily for use on medium to large material handling vehicles such as counterbalance or warehouse trucks. The Model 1236 is equally suitable for Light-On-Road passenger vehicles and utility vehicles. The larger Model 1238 is also intended for use on all heavy-duty applications such as Tow Tractors and Airport Ground Support Equipment (GSE).

Patents Pending

www.curtisinstruments.com

Only Curtis AC can offer:

- **Curtis VCL -Vehicle Control Language** is an easy to use programming language that allows vehicle developers to write powerful logic functions and create a 'virtual system controller'. Curtis offers customers VCL development tools and training. Curtis also provides a VCL service where Curtis engineers will work with the OEM to create any custom VCL code required.
- **Indirect Field Orientation (IFO) vector control** algorithm generates the maximum possible torque and efficiency across the entire speed range. Advanced Curtis IFO vector control provides superb drive 'feel', improved speed regulation and increased gradeability.
- **Curtis Auto-Tune** function enables quick and easy characterization of the AC motor without having to remove it from the vehicle. Curtis AC controllers are fully compatible with any brand of AC motor.
- **Dual-Drive functionality** is standard, allowing correct control of vehicles such as 3-wheel counterbalance trucks or other applications featuring twin traction motors. This function ensures smooth and safe operation, minimal tire wear and correct load sharing between the traction motors at all times.
- **Configurable CANbus** connection allows communication with other CANbus enabled devices. These models are CANopen compatible and can be further customized and configured using VCL.
- **Integrated System Controller** - More than just motor controllers, they are also powerful system controllers. They feature a comprehensive allocation of multi-function I/O pins for use as analog inputs, digital inputs, contactor coil drivers and proportional valve drivers. In addition to this local I/O, these controllers can use VCL to map and configure the remote I/O available on other CANbus devices, send messages to CAN displays and thus control and monitor the entire system.

FEATURES

Advanced functionality, compact power

- High frequency, silent operation across the 0-300Hz stator frequency range.
- Models available for 350-650A output at 24-80V system voltages. These are true 2 minute RMS ratings, not short duration 'boost' ratings.
- Powerful operating system allows parallel processing of vehicle control tasks, motor control tasks and user configurable programmable logic.
- Advanced Pulse Width Modulation techniques produce low motor harmonics, low torque ripple and minimized heating losses, resulting in high efficiency.

MODEL 1236/1238

FEATURES continued

Unmatched Flexibility

- Programmable for either traction or pump applications.
- Field upgradeable software.
- Integrated Battery state-of-charge algorithm and hour meter.
- Multi-Mode™ provides user-selectable vehicle operating profiles.
- Fully-featured generic software and VCL for typical Warehouse Truck applications is included.
- Comprehensive programming options and VCL allow other applications to be easily supported.
- Curtis hand-held or PC Windows programming tools provide easy programming and powerful system diagnostic tools.
- Integrated status LED provides instant diagnostic indication.

Robust Safety and Reliability

- Insulated Metal Substrate power base provides superior heat transfer for increased reliability.
- Fail-Safe power component design.

- Redundant hardware watchdog timers.
- Reverse polarity protection on battery connections.
- Short circuit protection on all output drivers.
- Thermal cutback, warning, and automatic shutdown provide protection to motor and controller.
- Rugged sealed housing and connectors meet IP65 environmental sealing standards for use in harsh environments.

Meets or complies with relevant US and International Regulations

EMC: Designed to the requirements of EN12895

Safety: Designed to the requirements of EN1175

IP65 Rated per IEC 529

UL recognized

Regulatory compliance of the complete vehicle system with the controller installed is the responsibility of the vehicle OEM.

MODEL CHART

Model	Battery Voltage V	2 Min RMS Current Rating Arms (A)	2 Min RMS Power Rating (kVA)
1236-44XX	24-36	400	16.6
1236-45XX	24-36	500	20.9
1238-46XX	24-36	650	25.4
1236-53XX	36-48	350	19.7
1236-54XX	36-48	450	24.8
1238-54XX	36-48	450	25.5
1238-56XX	36-48	650	36.3
1236-63XX	48-80	300	28.1
1238-65XX	48-80	550	51.3

SYSTEM ACCESSORIES



The Curtis Model 840 LCD Multifunction display contains 8 large, easy to read characters to provide display of battery discharge (BDI), hour meter and error messages. Built-in backlight is also available.



The Curtis model 1352 CANbus I/O expansion module features 9 I/O pins, including 6 proportional valve drivers. This module can be used to further expand the I/O capability of Curtis AC motor controllers using VCL.



The Curtis Model 1311 Handheld Programmer is ideal for setting parameters and performing diagnostic functions.

Contact Curtis to obtain the VCL Vehicle Control Language compiler and development tools.

MODEL 1236/1238

CONNECTOR WIRING

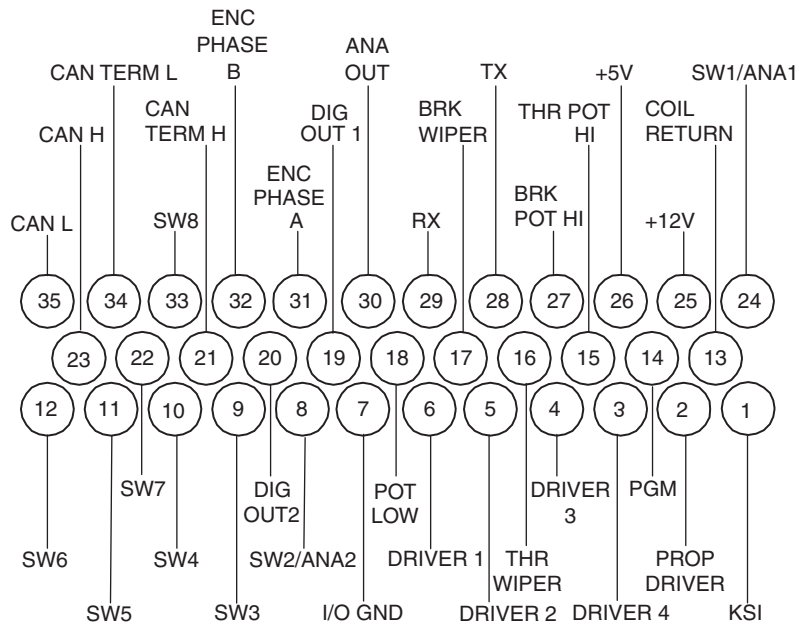

DIMENSIONS mm

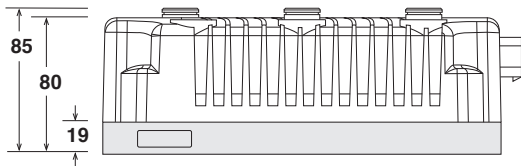
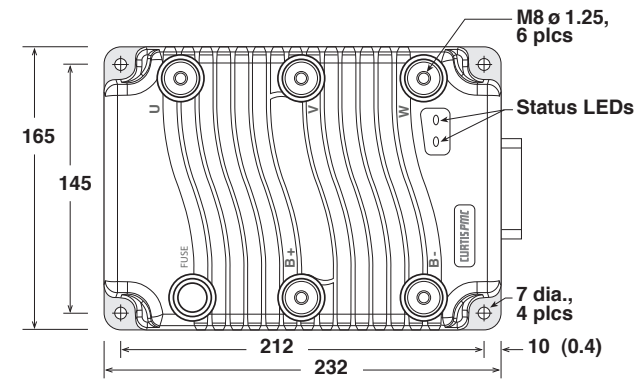

1236

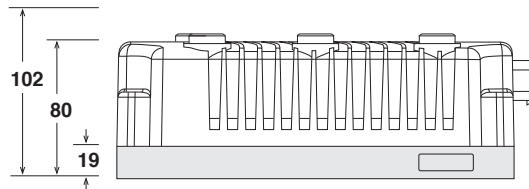
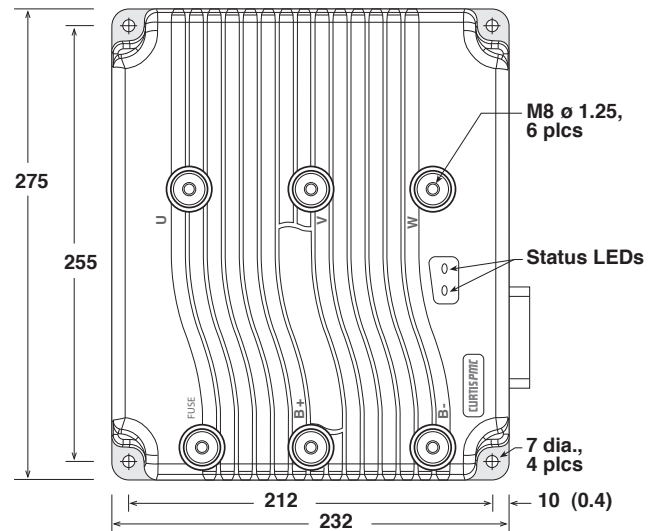

1238

MODEL 1236/1238

TYPICAL WIRING

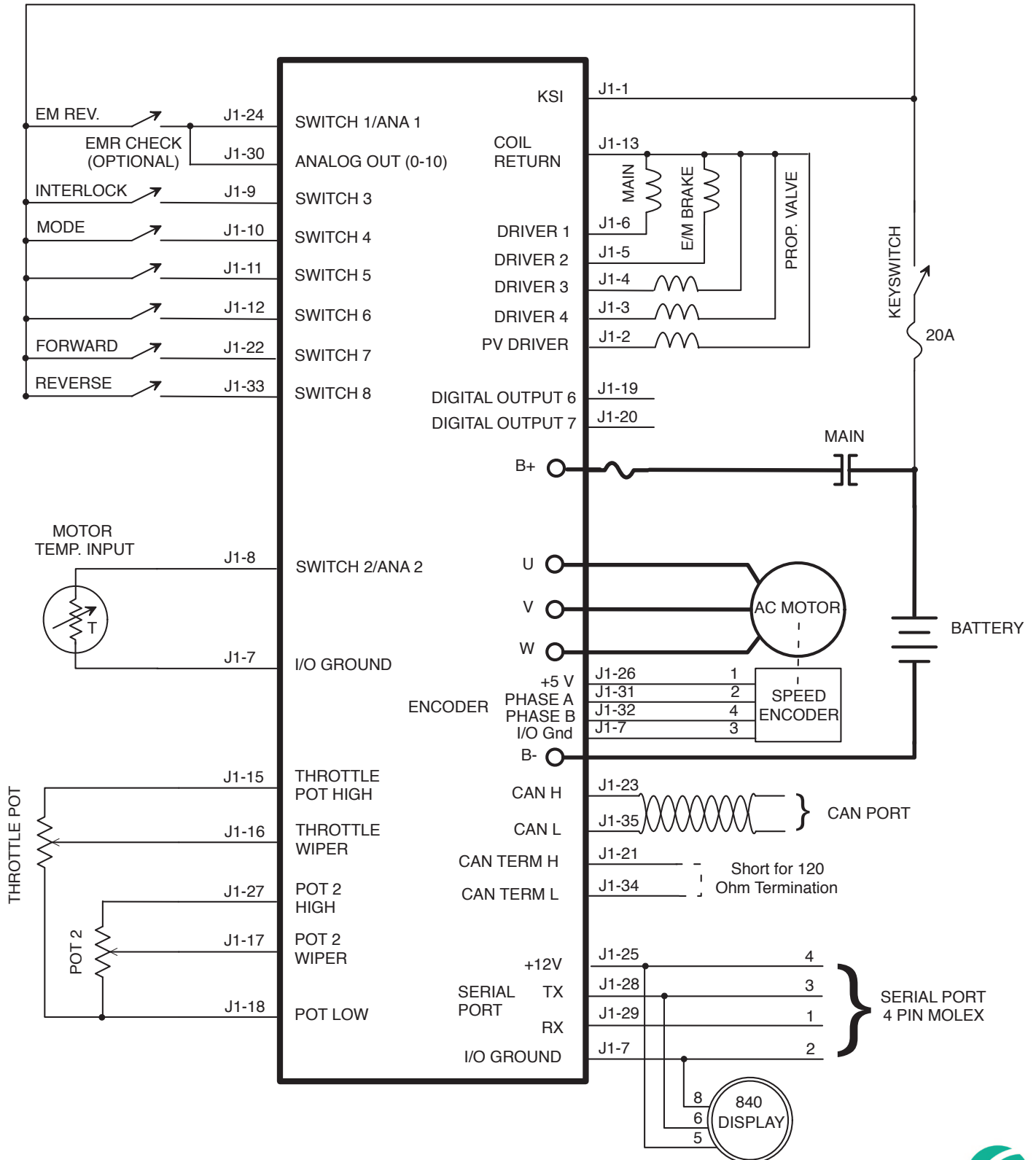

WARRANTY Two year limited warranty from time of delivery.

